

Product Description

- ◆ 10-32VDC Input
- ◆ Internal RC/MOV Protection Circuit
- ◆ Automatic Phase Correction, Phase Sequence Detection or Phase Loss Protection Function (Option)
- ◆ RoHS Compliant



Ordering Information

KMTYM	380	D	25	R	P	-24	F	-N
KMTYM Series	Load Voltage 380: 380VAC	DC Control	Load Current 15: 15Amp 25: 25Amp	Blank: Zero Crossing R: Random-on	Blank: Common Cathod P: Common Anode	Control Voltage 24: 10~32VDC	F: Three Phase Switch Blank: Two Phase Switch	Blank: with automatic phase correction function N: without automatic phase correction function

		15A	25A
Common Cathod	Two Phase Switch	KMTYM380D15-24	KMTYM380D25-24
		KMTYM380D15R-24	KMTYM380D25R-24
		KMTYM380D15-24-N	KMTYM380D25-24-N
	Three Phase Switch	KMTYM380D15R-24-N	KMTYM380D25R-24-N
		KMTYM380D15-24F	KMTYM380D25-24F
		KMTYM380D15R-24F	KMTYM380D25R-24F
Common Anode	Two Phase Switch	KMTYM380D15-24F-N	KMTYM380D25-24F-N
		KMTYM380D15R-24F-N	KMTYM380D25R-24F-N
		KMTYM380D15P-24	KMTYM380D25P-24
	Three Phase Switch	KMTYM380D15RP-24	KMTYM380D25RP-24
		KMTYM380D15P-24-N	KMTYM380D25P-24-N
		KMTYM380D15RP-24-N	KMTYM380D25RP-24-N
		KMTYM380D15P-24F	KMTYM380D25P-24F
		KMTYM380D15RP-24F	KMTYM380D25RP-24F
		KMTYM380D15P-24F-N	KMTYM380D25P-24F-N
		KMTYM380D15RP-24F-N	KMTYM380D25RP-24F-N

General Specifications

Input Specifications (Ta=25°C)		
Control Voltage Range	10-32VDC	
Must Turn-on Voltage	10VDC	
Must Turn-off Voltage	4VDC	
Maximum Input Current	Common Cathod	35mA@32VDC
	Common Anode	18mA@32VDC
Minimum Reversible Switching Time	80±10ms	

General Specifications

Output Specifications (Ta=25°C)		
Load Voltage Range	24-440VAC	
Maximum Transient Overvoltage	800Vpk	
Minimum Load Current	100mA	
Maximum Turn-off Time	20ms	
Maximum Surge Current (@10ms)	15A	150A
	25A	250A
Maximum Off-State Leakage Current@Rated Load Voltage	5mA	
Maximum On-State Voltage Drop@Rated Current	1.7Vrms	
Minimum Off-State dv/dt@Maximum Rated Voltage	200V/μs	

General Specifications (Ta=25°C)		
Dielectric Strength (50/60Hz)	Input/Output	4000Vrms
	Input, output/Base	2500Vrms
Minimum Insulation Resistance (@500VDC)	1000MΩ	
Ambient Temperature Range	-30°C ~ +80°C	
Storage Temperature Range	-30°C ~ +100°C	
Pulse Immunity Level	IEC61000-4-4	4kV/100kHz
Surge Immunity Level	IEC61000-4-5	2kV/common mould, 1kV/different mould
Electrostatic Discharge Immunity Level	IEC61000-4-2	4kV/contact discharge, 8kV/air discharge

General Specifications (Ta=25°C)		
Weight (Typical)	180g	
Working Status Indication	LED1	Forward Indication
	LED2	Reverse Indication
	LED3	Three-phase Power Status Indication

Applications

Three phase motor reversing control, such as the valve controls, and etc.

Outline Dimensions

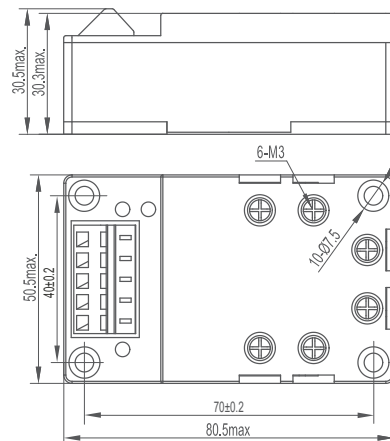

Wiring Diagram

Common Cathode

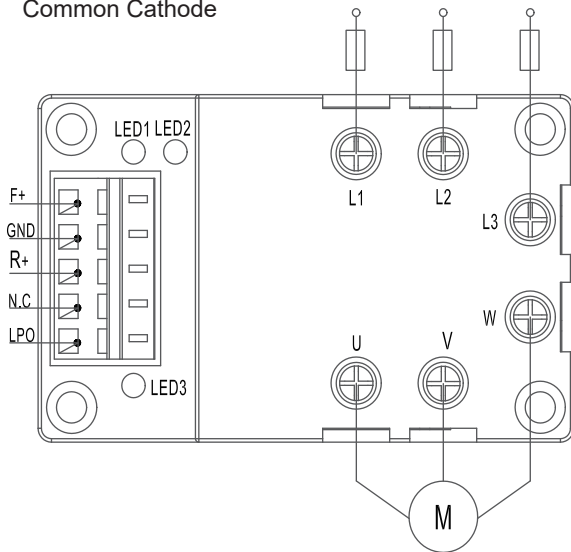

Wiring Instructions:

- F+: Forwarding control should input anode;
- GND: Control power supply should connect with cathode;
- R+: Reversing control should input anode;
- N.C.: No Connection
- LPO: Phase loss output, high impedance status when there is phase loss in three-phase electricity.
- Max. output current is 50mA;
- Note: there is no connection wire in LPO terminal when the product does not have phase loss protection or automatic phase correction function.

Common Anode

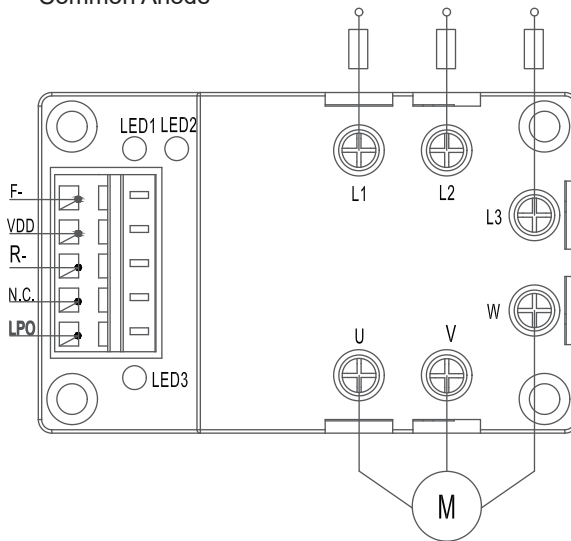

Wiring Instructions:

- F-: Forwarding control should input cathode;
- VDD: Control power supply should connect with anode, 10-32VDC;
- R-: Reversing control should input cathode;
- N.C.: No Connection
- LPO: Phase loss output, high impedance status when there is phase loss in three-phase electricity.
- Max. output current is 50mA;
- Note: there is no connection wire in LPO terminal when the product does not have phase loss protection or automatic phase correction function.

Thermal Derating Curve

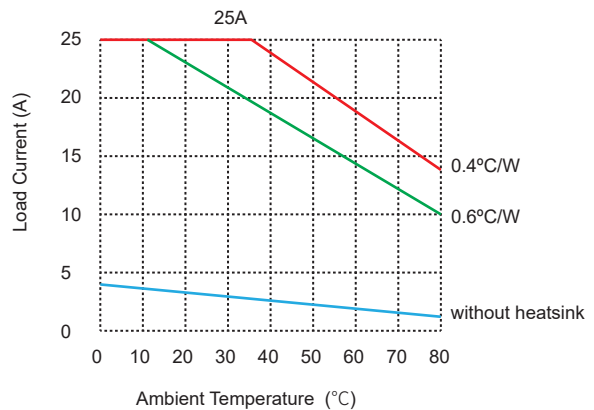
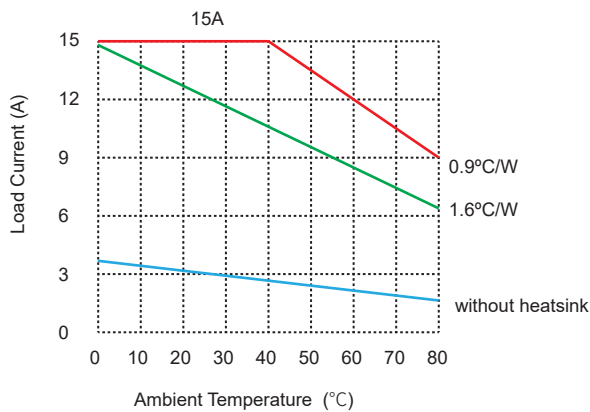

General Notes

1. Relay must be mounted to proper sized heat sink based on thermal curves. Thermal grease or a thermal pad must be used between relay .
2. When connecting wiring to SSR please ensure screws are torqued down properly output (0.58-0.98)N·m,5.13-8.67(lb-in)
3. When the operation temperature is high, please consider the derating as per the thermal curve.